

**JOHN DEERE**  
**WORLDWIDE COMMERCIAL & CONSUMER**  
**EQUIPMENT DIVISION**

---

**Gator Utility Vehicles™**  
**TX and TX Turf**

TM2241 MARCH 2005

**TECHNICAL MANUAL**



**JOHN DEERE**

North American Version  
Litho in U.S.A.



# INTRODUCTION

## Manual Description

This technical manual is written for an experienced technician and contains sections that are specifically for this product. It is a part of a total product support program.

The manual is organized so that all the information on a particular system is kept together. The order of grouping is as follows:

- Table of Contents
- Specifications and Information
- Identification Numbers
- Tools and Materials
- Component Location
- Schematics and Harnesses
- Theory of Operation
- Operation and Diagnostics
- Diagnostics
- Tests and Adjustments
- Repair
- Other

***NOTE: Depending on the particular section or system being covered, not all of the above groups may be used.***

The bleed tabs for the pages of each section will align with the sections listed on this page. Page numbering is consecutive from the beginning of the Safety section through the last section.

We appreciate your input on this manual. If you find any errors or want to comment on the layout of the manual please contact us.

**Safety**

**Specifications and Information**

**Engine - Gas**

**Electrical**

**Power Train**

**Steering**

**Brakes**

**Miscellaneous**

All information, illustrations and specifications in this manual are based on the latest information at the time of publication. The right is reserved to make changes at any time without notice.

COPYRIGHT© 2005  
Deere & Co.  
John Deere Worldwide Commercial and  
Consumer Equipment Division  
All rights reserved  
Previous Editions  
COPYRIGHT©

# INTRODUCTION

---

---

# SAFETY

## Recognize Safety Information

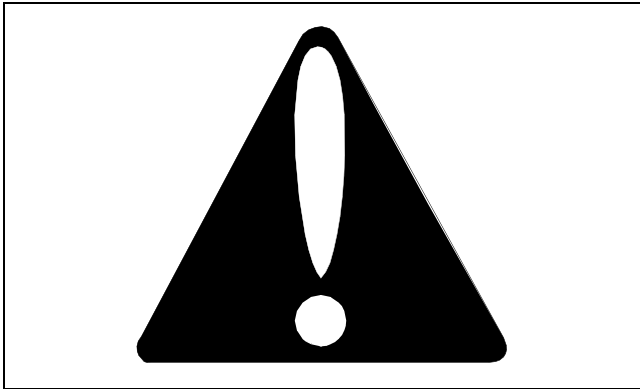

MIF

This is the safety-alert symbol. When you see this symbol on your machine or in this manual, be alert to the potential for personal injury.

Follow recommended precautions and safe servicing practices.

## Understand Signal Words

A signal word - DANGER, WARNING, or CAUTION - is used with the safety-alert symbol. DANGER identifies the most serious hazards.

DANGER or WARNING safety signs are located near specific hazards. General precautions are listed on CAUTION safety signs. CAUTION also calls attention to safety messages in this manual.

## Replace Safety Signs

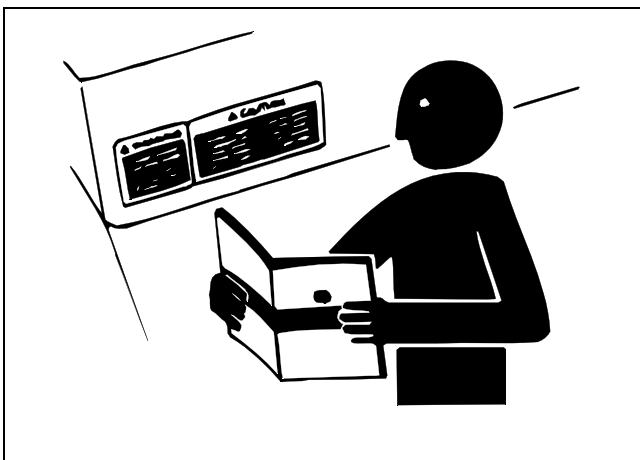

MIF

Replace missing or damaged safety signs. See the machine operator's manual for correct safety sign placement.

## Handle Fluids Safely - Avoid Fires

### Be Prepared For Emergencies

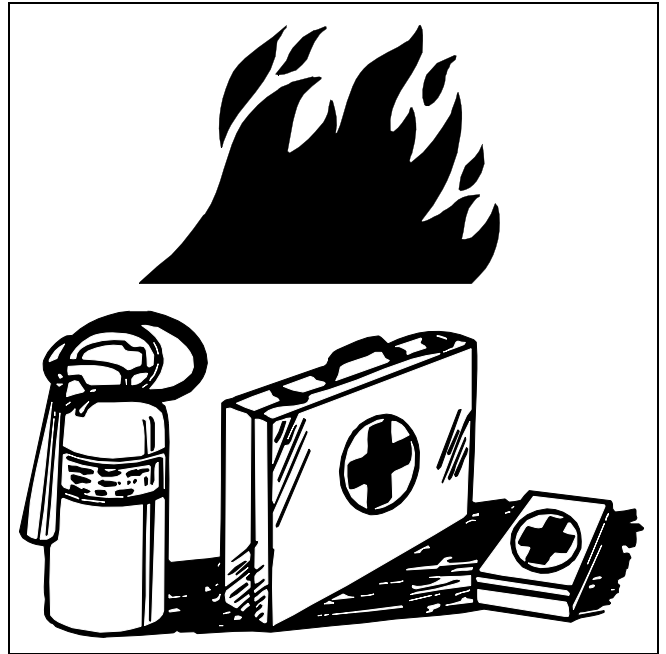

MIF

- When you work around fuel, do not smoke or work near heaters or other fire hazards.
- Store flammable fluids away from fire hazards. Do not incinerate or puncture pressurized containers.
- Make sure machine is clean of trash, grease, and debris.
- Do not store oily rags; they can ignite and burn spontaneously.
- Be prepared if a fire starts.
- Keep a first aid kit and fire extinguisher handy.
- Keep emergency numbers for doctors, ambulance service, hospital, and fire department near your telephone.

## Use Care In Handling and Servicing Batteries

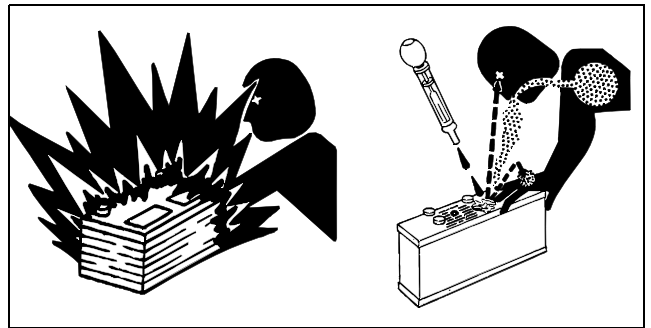

MIF

# SAFETY

## Prevent Battery Explosions

- Keep sparks, lighted matches, and open flame away from the top of battery. Battery gas can explode.
- Never check battery charge by placing a metal object across the posts. Use a volt-meter or hydrometer.
- Do not charge a frozen battery; it may explode. Warm battery to 16°C (60°F).

## Prevent Acid Burns

- Sulfuric acid in battery electrolyte is poisonous. It is strong enough to burn skin, eat holes in clothing, and cause blindness if splashed into eyes.

### Avoid acid burns by:

1. Filling batteries in a well-ventilated area.
2. Wearing eye protection and rubber gloves.
3. Avoiding breathing fumes when electrolyte is added.
4. Avoiding spilling or dripping electrolyte.
5. Use proper jump start procedure.

### If you spill acid on yourself:

1. Flush your skin with water.
2. Apply baking soda or lime to help neutralize the acid.
3. Flush your eyes with water for 10 - 15 minutes.
4. Get medical attention immediately.

### If acid is swallowed:

1. Drink large amounts of water or milk.
2. Then drink milk of magnesia, beaten eggs, or vegetable oil.
3. Get medical attention immediately.

## Wear Protective Clothing

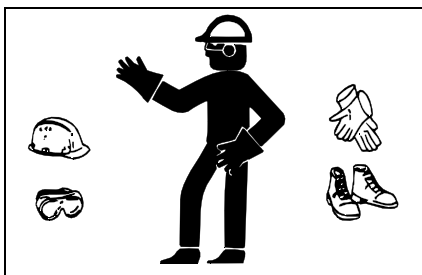

MIF

Wear close fitting clothing and safety equipment appropriate to the job.

Prolonged exposure to loud noise can cause impairment or loss of hearing. Wear a suitable hearing protective device

such as earmuffs or earplugs to protect against objectionable or uncomfortable loud noises.

Operating equipment safely requires the full attention of the operator. Do not wear radio or music headphones while operating machine.

## Use Care Around High-pressure Fluid Lines

### Avoid High-Pressure Fluids



MIF

Escaping fluid under pressure can penetrate the skin causing serious injury.

Avoid injury from escaping fluid under pressure by stopping the engine and relieving pressure in the system before disconnecting or connecting hydraulic or other lines. Tighten all connections before applying pressure.

Search for leaks with a piece of cardboard. Protect hands and body from high pressure fluids.

If an accident occurs, see a doctor immediately. Any fluid injected into the skin must be surgically removed within a few hours or gangrene may result. Doctors unfamiliar with this type of injury should reference a knowledgeable medical source. Such information is available from Deere & Company Medical Department in Moline, Illinois, U.S.A.

### Avoid Heating Near Pressurized Fluid Lines



MIF

Flammable spray can be generated by heating near pressurized fluid lines, resulting in severe burns to yourself and bystanders. Do not heat by welding, soldering, or using a torch near pressurized fluid lines or other flammable materials. Pressurized lines can be accidentally cut when heat goes beyond the immediate flame area.

# SAFETY

## Service Machines Safely

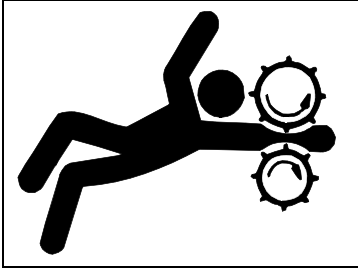

MIF

Tie long hair behind your head. Do not wear a necktie, scarf, loose clothing, or necklace when you work near machine tools or moving parts. If these items were to get caught, severe injury could result.

Remove rings and other jewelry to prevent electrical shorts and entanglement in moving parts.

## Use Proper Tools

Use tools appropriate to the work. Makeshift tools and procedures can create safety hazards. Use power tools only to loosen threaded parts and fasteners. For loosening and tightening hardware, use the correct size tools. **DO NOT** use U.S. measurement tools on metric fasteners. Avoid bodily injury caused by slipping wrenches. Use only service parts meeting John Deere specifications.

## Parking Safely

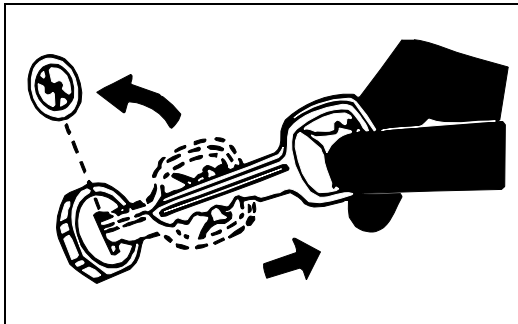

MIF

1. Stop machine on a level surface, not on a slope.
2. Disengage and stop attachments.
3. Lower attachments to the ground.
4. Lock park brake.
5. Stop engine.
6. Remove key.
7. Wait for engine and all moving parts to stop before you leave the operator's station.
8. Close fuel shut-off valve, if your machine is equipped.

## Support Machine Properly and Use Proper Lifting Equipment

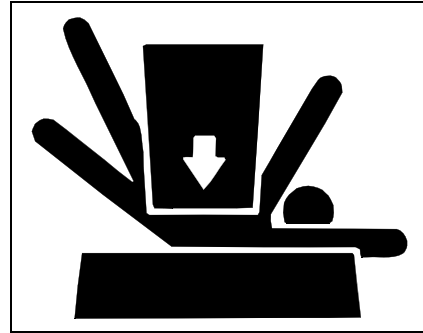

MIF

If you must work on a lifted machine or attachment, securely support the machine or attachment.

Do not support the machine on cinder blocks, hollow tiles, or props that may crumble under continuous load. Do not work under a machine that is supported solely by a jack. Follow recommended procedures in this manual.

Lifting heavy components incorrectly can cause severe injury or machine damage. Follow recommended procedure for removal and installation of components in the manual.

## Work In Clean Area

### Before starting a job:

1. Clean work area and machine.
2. Make sure you have all necessary tools to do your job.
3. Have the right parts on hand.
4. Read all instructions thoroughly; do not attempt shortcuts.

## Using High Pressure Washers

Directing pressurized water at electronic/electrical components or connectors, bearings, hydraulic seals, fuel injection pumps or other sensitive parts and components may cause product malfunctions. Reduce pressure and spray at a 45 to 90 degree angle.

## Illuminate Work Area Safely

Illuminate your work area adequately but safely. Use a portable safety light for working inside or under the machine. Make sure the bulb is enclosed by a wire cage. The hot filament of an accidentally broken bulb can ignite spilled fuel or oil.

# SAFETY

## Work In Ventilated Area

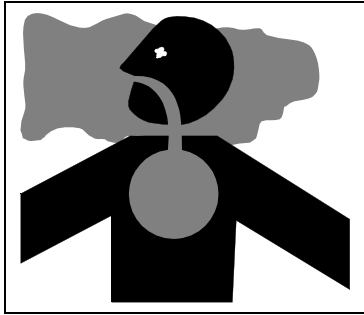

MIF

Engine exhaust fumes can cause sickness or death. If it is necessary to run an engine in an enclosed area, remove the exhaust fumes from the area with an exhaust pipe extension.

If you do not have an exhaust pipe extension, open the doors and get outside air into the area.

## Warning: California Proposition 65 Warning

Gasoline engine exhaust from this product contains chemicals known to the State of California to cause cancer, birth defects, or other reproductive harm.

Diesel engine exhaust and some of its constituents are known to the State of California to cause cancer, birth defects, and other reproductive harm.

## Remove Paint Before Welding or Heating

Avoid potentially toxic fumes and dust. Hazardous fumes can be generated when paint is heated by welding, soldering, or using a torch. Do all work outside or in a well ventilated area. Dispose of paint and solvent properly. Remove paint before welding or heating: If you sand or grind paint, avoid breathing the dust. Wear an approved respirator. If you use solvent or paint stripper, remove stripper with soap and water before welding. Remove solvent or paint stripper containers and other flammable material from area. Allow fumes to disperse at least 15 minutes before welding or heating.

## Avoid Harmful Asbestos Dust

Avoid breathing dust that may be generated when handling components containing asbestos fibers. Inhaled asbestos fibers may cause lung cancer.

Components in products that may contain asbestos fibers are brake pads, brake band and lining assemblies, clutch plates, and some gaskets. The asbestos used in these components is usually found in a resin or sealed in some way. Normal handling is not hazardous as long as airborne dust containing asbestos is not generated.

Avoid creating dust. Never use compressed air for cleaning. Avoid brushing or grinding material containing asbestos. When servicing, wear an approved respirator. A special vacuum cleaner is recommended to clean asbestos. If not available, apply a mist of oil or water on the material containing asbestos. Keep bystanders away from the area.

## Service Tires Safely

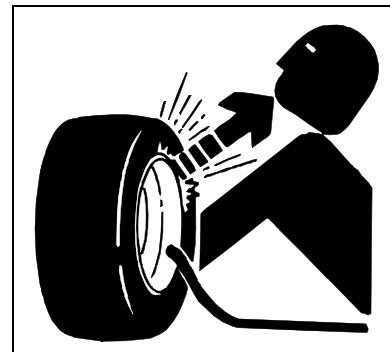

MIF

Explosive separation of a tire and rim parts can cause serious injury or death.

Do not attempt to mount a tire unless you have the proper equipment and experience to perform the job.

Always maintain the correct tire pressure. Do not inflate the tires above the recommended pressure. Never weld or heat a wheel and tire assembly. The heat can cause an increase in air pressure resulting in a tire explosion. Welding can structurally weaken or deform the wheel.

When inflating tires, use a clip-on chuck and extension hose long enough to allow you to stand to one side and NOT in front of or over the tire assembly. Use a safety cage if available.

Check wheels for low pressure, cuts, bubbles, damaged rims or missing lug bolts and nuts.



# SAFETY

## Avoid Injury From Rotating Blades, Augers and PTO Shafts

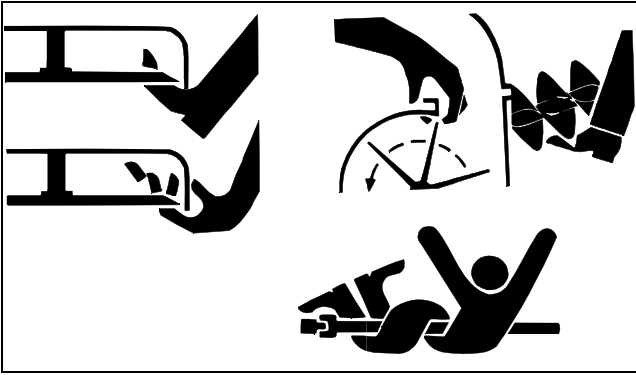

MIF

Keep hands and feet away while machine is running. Shut off power to service, lubricate or remove mower blades, augers or PTO shafts.

## Service Cooling System Safely

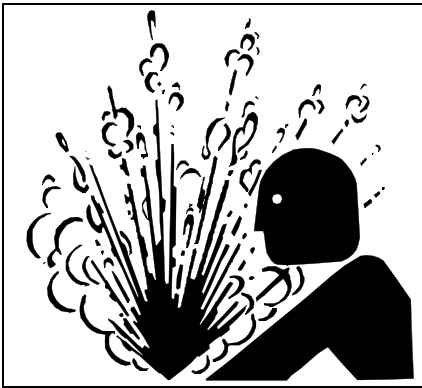

MIF

Explosive release of fluids from pressurized cooling system can cause serious burns.

Shut off machine. Only remove filler cap when cool enough to touch with bare hands. Slowly loosen cap to first stop to relieve pressure before removing completely.

## Handle Chemical Products Safely

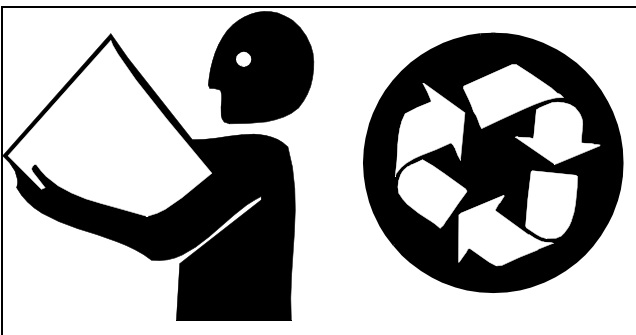

MIF

Direct exposure to hazardous chemicals can cause serious injury. Potentially hazardous chemicals used with John Deere equipment include such items as lubricants, coolants, paints, and adhesives.

A Material Safety Data Sheet (MSDS) provides specific details on chemical products: physical and health hazards, safety procedures, and emergency response techniques. Check the MSDS before you start any job using a hazardous chemical. That way you will know exactly what the risks are and how to do the job safely. Then follow procedures and recommended equipment.

## Dispose of Waste Properly

Improperly disposing of waste can threaten the environment and ecology. Potentially harmful waste used with John Deere equipment include such items as oil, fuel, coolant, brake fluid, filters, and batteries. Use leakproof containers when draining fluids. Do not use food or beverage containers that may mislead someone into drinking from them. Do not pour waste onto the ground, down a drain, or into any water source. Inquire on the proper way to recycle or dispose of waste from your local environmental or recycling center, or from your John Deere dealer.

## Live With Safety



MIF

Before returning machine to customer, make sure machine is functioning properly, especially the safety systems. Install all guards and shields.

# SAFETY

---

---



# SPECIFICATIONS AND INFORMATION TABLE OF CONTENTS

---

---

## Table of Contents

|  |           |
|--|-----------|
| <b>Fastener Torques</b> .....                    | <b>9</b>  |
| Metric Fastener Torque Values .....              | 9         |
| Inch Fastener Torque Values .....                | 10        |
| <b>O-Ring Seal Service Recommendations</b> ..... | <b>11</b> |
| Face Seal Fittings With Inch Stud Ends           |           |
| Torque .....                                     | 11        |
| Face Seal Fittings With Metric Stud Ends         |           |
| Torque .....                                     | 12        |
| O-Ring Face Seal Fittings .....                  | 13        |
| O-Ring Boss Fittings .....                       | 13        |
| Straight Fitting Or Special Nut Torques.....     | 14        |
| Metric Fastener Torque Value -                   |           |
| Grade 7 (Special) .....                          | 14        |
| <b>General Information</b> .....                 | <b>14</b> |
| Gasoline .....                                   | 14        |
| Gasoline Storage.....                            | 15        |
| 4 - Cycle Gasoline Engine Oil .....              | 15        |
| Break-In Engine Oil - 4-Cycle Gasoline.....      | 16        |
| Grease.....                                      | 16        |
| Chain Lubricant .....                            | 16        |
| Transaxle Oil .....                              | 16        |
| Alternative Lubricants.....                      | 17        |
| Synthetic Lubricants .....                       | 17        |
| Lubricant Storage .....                          | 17        |
| Mixing of Lubricants .....                       | 17        |
| Oil Filters .....                                | 17        |
| Brake Fluid .....                                | 17        |
| <b>Serial Number Locations</b> .....             | <b>18</b> |
| Product Serial Number .....                      | 18        |
| Engine Serial Number Location.....               | 18        |
| Transaxle Serial Number Location .....           | 18        |

# SPECIFICATIONS AND INFORMATION TABLE OF CONTENTS

---

---



# SPECIFICATIONS AND INFORMATION FASTENER TORQUES

## Fastener Torques

### Metric Fastener Torque Values

|   |  |  |  |  |
|---|--|--|--|--|
| <b>Property Class and Head Markings</b> |  |  |  |  |
| <b>Property Class and Nut Markings</b>  |  |  |  |  |

MIF

| SIZE | Class 4.8    |       | Class 8.8 or 9.8 |       |              |       | Class 10.9 |       |              |       | Class 12.9 |       |              |       |       |       |
|------|--------------|-------|------------------|-------|--------------|-------|------------|-------|--------------|-------|------------|-------|--------------|-------|-------|-------|
|      | Lubricated a |       | Dry a            |       | Lubricated a |       | Dry a      |       | Lubricated a |       | Dry a      |       | Lubricated a |       | Dry a |       |
|      | N•m          | lb-ft | N•m              | lb-ft | N•m          | lb-ft | N•m        | lb-ft | N•m          | lb-ft | N•m        | lb-ft | N•m          | lb-ft | N•m   | lb-ft |
| M6   | 4.8          | 3.5   | 6                | 4.5   | 9            | 6.5   | 11         | 8.5   | 13           | 9.5   | 17         | 12    | 15           | 11.5  | 19    | 14.5  |
| M8   | 12           | 8.5   | 15               | 11    | 22           | 16    | 28         | 20    | 32           | 24    | 40         | 30    | 37           | 28    | 47    | 35    |
| M10  | 23           | 17    | 29               | 21    | 43           | 32    | 55         | 40    | 63           | 47    | 80         | 60    | 75           | 55    | 95    | 70    |
| M12  | 40           | 29    | 50               | 37    | 75           | 55    | 95         | 70    | 110          | 80    | 140        | 105   | 130          | 95    | 165   | 120   |
| M14  | 63           | 47    | 80               | 60    | 120          | 88    | 150        | 110   | 175          | 130   | 225        | 165   | 205          | 150   | 260   | 109   |
| M16  | 100          | 73    | 125              | 92    | 190          | 140   | 240        | 175   | 275          | 200   | 350        | 225   | 320          | 240   | 400   | 300   |
| M18  | 135          | 100   | 175              | 125   | 260          | 195   | 330        | 250   | 375          | 275   | 475        | 350   | 440          | 325   | 560   | 410   |
| M20  | 190          | 140   | 240              | 180   | 375          | 275   | 475        | 350   | 530          | 400   | 675        | 500   | 625          | 460   | 800   | 580   |
| M22  | 260          | 190   | 330              | 250   | 510          | 375   | 650        | 475   | 725          | 540   | 925        | 675   | 850          | 625   | 1075  | 800   |
| M24  | 330          | 250   | 425              | 310   | 650          | 475   | 825        | 600   | 925          | 675   | 1150       | 850   | 1075         | 800   | 1350  | 1000  |
| M27  | 490          | 360   | 625              | 450   | 950          | 700   | 1200       | 875   | 1350         | 1000  | 1700       | 1250  | 1600         | 1150  | 2000  | 1500  |
| M30  | 675          | 490   | 850              | 625   | 1300         | 950   | 1650       | 1200  | 1850         | 1350  | 2300       | 1700  | 2150         | 1600  | 2700  | 2000  |
| M33  | 900          | 675   | 1150             | 850   | 1750         | 1300  | 2200       | 1650  | 2500         | 1850  | 3150       | 2350  | 2900         | 2150  | 3700  | 2750  |
| M36  | 1150         | 850   | 1450             | 1075  | 2250         | 1650  | 2850       | 2100  | 3200         | 2350  | 4050       | 3000  | 3750         | 2750  | 4750  | 3500  |

DO NOT use these hand torque values if a different torque value or tightening procedure is given for a specific application. Torque values listed are for general use only and include a  $\pm 10\%$  variance factor. Check tightness of fasteners periodically. DO NOT use air powered wrenches.

Shear bolts are designed to fail under predetermined loads. Always replace shear bolts with identical grade.

Fasteners should be replaced with the same grade. Make sure fastener threads are clean and that you properly start thread engagement. This will prevent them from failing when tightening.

When bolt and nut combination fasteners are used, torque values should be applied to the NUT instead of the bolt head.







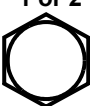

Tighten toothed or serrated-type lock nuts to the full torque value.

a "Lubricated" means coated with a lubricant such as engine oil, or fasteners with phosphate and oil coatings. "Dry" means plain or zinc plated (yellow dichromate - Specification JDS117) without any lubrication.

Reference: JDS - G200.

# SPECIFICATIONS AND INFORMATION FASTENER TORQUES

## Inch Fastener Torque Values

|                                    |   |   |  |
|------------------------------------|---|---|--|
| <b>SAE Grade and Head Markings</b> | 1 or 2 <sup>b</sup><br>No Marks  | 5    5.1    5.2<br>   | 8    8.2<br>  |
| <b>SAE Grade and Nut Markings</b>  | 2<br>No Marks                    | 5<br>  | 8<br>  |

MIF

| SIZE  | Grade 1      |       | Grade 2b |       |              |       | Grade 5, 5.1 or 5.2 |       |              |       | Grade 8 or 8.2 |       |              |       |       |       |
|-------|--------------|-------|----------|-------|--------------|-------|---------------------|-------|--------------|-------|----------------|-------|--------------|-------|-------|-------|
|       | Lubricated a |       | Dry a    |       | Lubricated a |       | Dry a               |       | Lubricated a |       | Dry a          |       | Lubricated a |       | Dry a |       |
|       | N•m          | lb-ft | N•m      | lb-ft | N•m          | lb-ft | N•m                 | lb-ft | N•m          | lb-ft | N•m            | lb-ft | N•m          | lb-ft | N•m   | lb-ft |
| 1/4   | 3.7          | 2.8   | 4.7      | 3.5   | 6            | 4.5   | 7.5                 | 5.5   | 9.5          | 7     | 12             | 9     | 13.5         | 10    | 17    | 12.5  |
| 5/16  | 7.7          | 5.5   | 10       | 7     | 12           | 9     | 15                  | 11    | 20           | 15    | 25             | 18    | 28           | 21    | 35    | 26    |
| 3/8   | 14           | 10    | 17       | 13    | 22           | 16    | 27                  | 20    | 35           | 26    | 44             | 33    | 50           | 36    | 63    | 46    |
| 7/16  | 22           | 16    | 28       | 20    | 35           | 26    | 44                  | 32    | 55           | 41    | 70             | 52    | 80           | 58    | 100   | 75    |
| 1/2   | 33           | 25    | 42       | 31    | 53           | 39    | 67                  | 50    | 85           | 63    | 110            | 80    | 120          | 90    | 150   | 115   |
| 9/16  | 48           | 36    | 60       | 45    | 75           | 56    | 95                  | 70    | 125          | 90    | 155            | 115   | 175          | 130   | 225   | 160   |
| 5/8   | 67           | 50    | 85       | 62    | 105          | 78    | 135                 | 100   | 170          | 125   | 215            | 160   | 215          | 160   | 300   | 225   |
| 3/4   | 120          | 87    | 150      | 110   | 190          | 140   | 240                 | 175   | 300          | 225   | 375            | 280   | 425          | 310   | 550   | 400   |
| 7/8   | 190          | 140   | 240      | 175   | 190          | 140   | 240                 | 175   | 490          | 360   | 625            | 450   | 700          | 500   | 875   | 650   |
| 1     | 290          | 210   | 360      | 270   | 290          | 210   | 360                 | 270   | 725          | 540   | 925            | 675   | 1050         | 750   | 1300  | 975   |
| 1-1/8 | 470          | 300   | 510      | 375   | 470          | 300   | 510                 | 375   | 900          | 675   | 1150           | 850   | 1450         | 1075  | 1850  | 1350  |
| 1-1/4 | 570          | 425   | 725      | 530   | 570          | 425   | 725                 | 530   | 1300         | 950   | 1650           | 1200  | 2050         | 1500  | 2600  | 1950  |
| 1-3/8 | 750          | 550   | 950      | 700   | 750          | 550   | 950                 | 700   | 1700         | 1250  | 2150           | 1550  | 2700         | 2000  | 3400  | 2550  |
| 1-1/2 | 1000         | 725   | 1250     | 925   | 990          | 725   | 1250                | 930   | 2250         | 1650  | 2850           | 2100  | 3600         | 2650  | 4550  | 3350  |

DO NOT use these hand torque values if a different torque value or tightening procedure is given for a specific application. Torque values listed are for general use only and include a ±10% variance factor. Check tightness of fasteners periodically. DO NOT use air powered wrenches.

Shear bolts are designed to fail under predetermined loads. Always replace shear bolts with identical grade.

Fasteners should be replaced with the same grade. Make sure fastener threads are clean and that you properly start thread engagement. This will prevent them from failing when tightening.

When bolt and nut combination fasteners are used, torque values should be applied to the NUT instead of the bolt

head.

Tighten toothed or serrated-type lock nuts to the full torque value.

a "Lubricated" means coated with a lubricant such as engine oil, or fasteners with phosphate and oil coatings. "Dry" means plain or zinc plated (yellow dichromate - Specification JDS117) without any lubrication.

b "Grade 2" applies for hex cap screws (Not Hex Bolts) up to 152 mm (6 in.) long. "Grade 1" applies for hex cap screws over 152 mm (6 in.) long, and for all other types of bolts and screws of any length.

Reference: JDS - G200

# SPECIFICATIONS AND INFORMATION O-RING SEAL SERVICE

## O-Ring Seal Service Recommendations

### Face Seal Fittings With Inch Stud Ends Torque

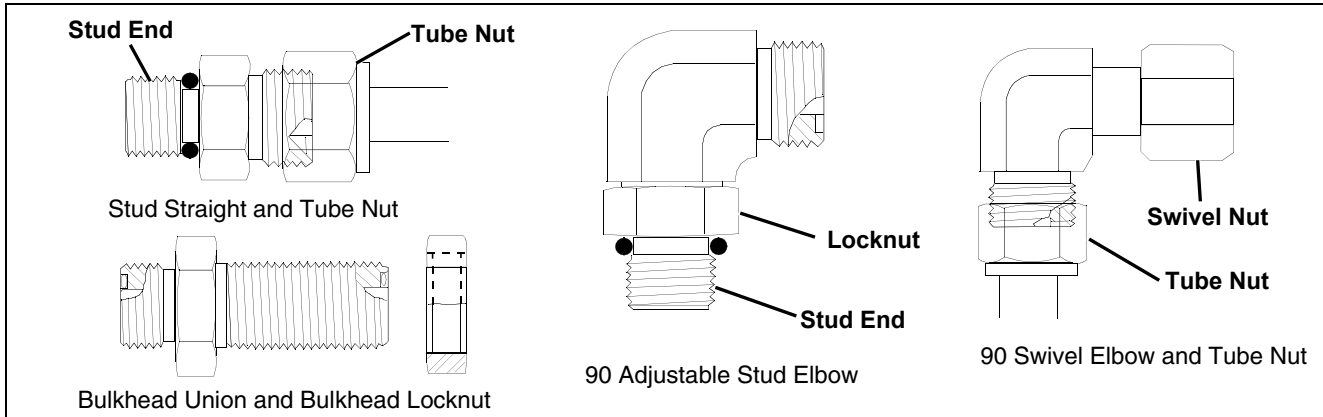

MIF

| Nominal Tube OD/Hose ID |              |           |       | Face Seal Tube/Hose End |                                   |     |                                |       | O-Ring Stud Ends |  |       |     |
|-------------------------|--------------|-----------|-------|-------------------------|-----------------------------------|-----|--------------------------------|-------|------------------|--|-------|-----|
| Metric Tube OD          | Inch Tube OD |           |       | Thread Size             | Tube Nut/<br>Swivel Nut<br>Torque |     | Bulkhead<br>Lock Nut<br>Torque |       | Thread Size      | Straight Fitting or<br>Lock Nut Torque |       |     |
|                         | mm           | Dash Size | in.   |                         | mm                                | in. | N•m                            | lb-ft |                  | N•m                                    | lb-ft | in. |
| 5                       | -3           | 0.188     | 4.76  |                         |                                   |     |                                |       | 3/8-24           | 8                                      | 6     |     |
| 6                       | -4           | 0.250     | 6.35  | 9/16-18                 | 16                                | 12  | 12                             | 9     | 7/16-20          | 12                                     | 9     |     |
| 8                       | -5           | 0.312     | 7.94  |                         |                                   |     |                                |       | 1/2-20           | 16                                     | 12    |     |
| 10                      | -6           | 0.375     | 9.52  | 11/16-16                | 24                                | 18  | 24                             | 18    | 9/16-18          | 24                                     | 18    |     |
| 12                      | -8           | 0.500     | 12.70 | 13/16-16                | 50                                | 37  | 46                             | 34    | 3/4-16           | 46                                     | 34    |     |
| 16                      | -10          | 0.625     | 15.88 | 1-14                    | 69                                | 51  | 62                             | 46    | 7/8-14           | 62                                     | 46    |     |
| 19                      | -12          | 0.750     | 19.05 | 1-3/16-12               | 102                               | 75  | 102                            | 75    | 1-1/16-12        | 102                                    | 75    |     |
| 22                      | -14          | 0.875     | 22.22 | 1-3/16-12               | 102                               | 75  | 102                            | 75    | 1-3/16-12        | 122                                    | 90    |     |
| 25                      | -16          | 1.000     | 25.40 | 1-7/16-12               | 142                               | 105 | 142                            | 105   | 1-5/16-12        | 142                                    | 105   |     |
| 32                      | -20          | 1.25      | 31.75 | 1-11/16-12              | 190                               | 140 | 190                            | 140   | 1-5/8-12         | 190                                    | 140   |     |
| 38                      | -24          | 1.50      | 38.10 | 2-12                    | 217                               | 160 | 217                            | 160   | 1-7/8-12         | 217                                    | 160   |     |

**NOTE: Torque tolerance is +15%, -20%**

# SPECIFICATIONS AND INFORMATION O-RING SEAL SERVICE

## Face Seal Fittings With Metric Stud Ends Torque

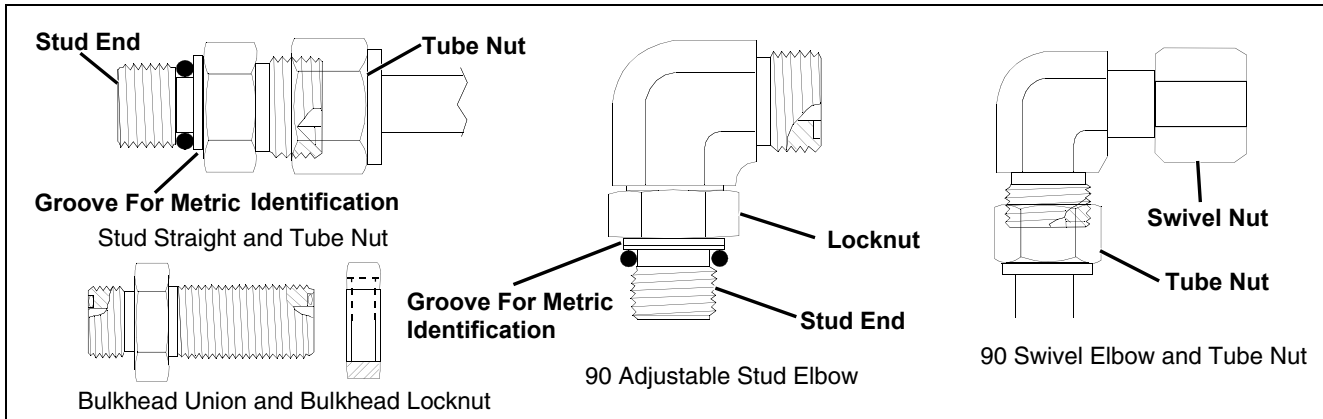

| Nominal Tube OD/Hose ID |              |       |       | Face Seal Tube/Hose End |          |                                   |     |                             |       | O-Ring Stud Ends, Straight Fitting or Lock Nut |          |                              |       |                    |     |
|-------------------------|--------------|-------|-------|-------------------------|----------|-----------------------------------|-----|-----------------------------|-------|--|----------|------------------------------|-------|--------------------|-----|
| Metric Tube OD          | Inch Tube OD |       |       | Thread Size             | Hex Size | Tube Nut/<br>Swivel Nut<br>Torque |     | Bulkhead Lock Nut<br>Torque |       | Thread Size                                    | Hex Size | Steel or Gray Iron<br>Torque |       | Aluminum<br>Torque |     |
|                         | Dash Size    | in.   | mm    |                         |          | in.                               | mm  | N•m                         | lb-ft |  |          | N•m                          | lb-ft | mm                 | mm  |
| 6                       | -4           | 0.250 | 6.35  | 9/16-18                 | 17       | 16                                | 12  | 12                          | 9     | M12X1.5  | 17       | 21                           | 15.5  | 9                  | 6.6 |
| 8                       | -5           | 0.312 | 7.94  |                         |          |                                   |     |                             |       |  |          |                              |       |                    |     |
|                         |              |       |       |                         |          |                                   |     |                             |       | M14X1.5  | 19       | 33                           | 24    | 15                 | 11  |
| 10                      | -6           | 0.375 | 9.52  | 11/16-16                | 22       | 24                                | 18  | 24                          | 18    | M16X1.5  | 22       | 41                           | 30    | 18                 | 13  |
| 12                      | -8           | 0.500 | 12.70 | 13/16-16                | 24       | 50                                | 37  | 46                          | 34    | M18X1.5  | 24       | 50                           | 37    | 21                 | 15  |
| 16                      | -10          | 0.625 | 15.88 | 1-14                    | 30       | 69                                | 51  | 62                          | 46    | M22X1.5  | 27       | 69                           | 51    | 28                 | 21  |
|                         | -12          | 0.750 | 19.05 | 1-3/16-12               | 36       | 102                               | 75  | 102                         | 75    | M27X2  | 32       | 102                          | 75    | 46                 | 34  |
| 22                      | -14          | 0.875 | 22.22 | 1-3/16-12               | 36       | 102                               | 75  | 102                         | 75    | M30X2  | 36       |                              |       |                    |     |
| 25                      | -16          | 1.000 | 25.40 | 1-7/16-12               | 41       | 142                               | 105 | 142                         | 105   | M33X2  | 41       | 158                          | 116   | 71                 | 52  |
| 28                      |              |       |       |                         |          |                                   |     |                             |       | M38X2  | 46       | 176                          | 130   | 79                 | 58  |
| 32                      | -20          | 1.25  | 31.75 | 1-11/16-12              | 50       | 190                               | 140 | 190                         | 140   | M42X2  | 50       | 190                          | 140   | 85                 | 63  |
| 38                      | -24          | 1.50  | 38.10 | 2-12                    | 60       | 217                               | 160 | 217                         | 160   | M48X2  | 55       | 217                          | 160   | 98                 | 72  |

**NOTE: Torque tolerance is +15%, -20%**



# SPECIFICATIONS AND INFORMATION O-RING SEAL SERVICE

## O-Ring Face Seal Fittings

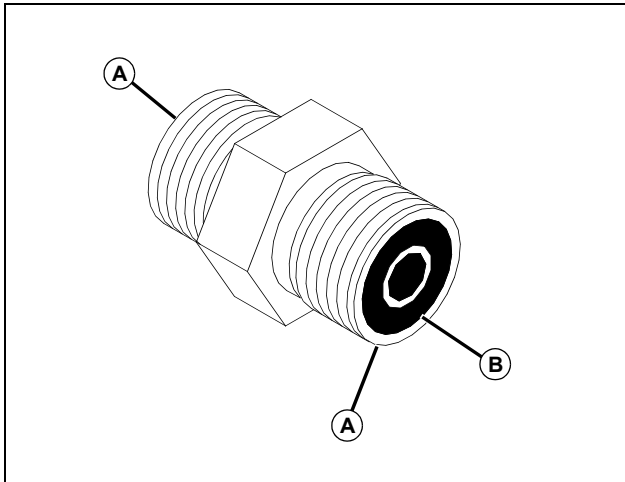

MIF

1. Inspect the fitting sealing surfaces (A). They must be free of dirt or defects.
2. Inspect the O-ring (B). It must be free of damage or defects.
3. Lubricate O-rings and install into groove using petroleum jelly to hold in place during assembly.
4. Index angle fittings and tighten by hand pressing joint together to insure O-ring remains in place.

**IMPORTANT: Avoid damage! DO NOT allow hoses to twist when tightening fittings. Use two wrenches to tighten hose connections; one to hold the hose, and the other to tighten the swivel fitting.**

5. Tighten fitting or nut to torque value shown on the chart per dash size stamped on the fitting.

## O-Ring Boss Fittings

1. Inspect boss O-ring boss seat. It must be free of dirt and defects. If repeated leaks occur, inspect for defects with a magnifying glass. Some raised defects can be removed with a slip stone.

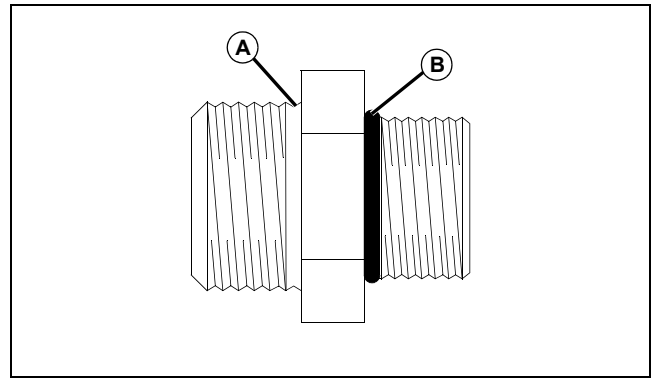

MIF

2. Put hydraulic oil or petroleum jelly on the O-ring (B). Place electrical tape over the threads to protect O-ring from nicks. Slide O-ring over the tape and into the groove (A) of fitting. Remove tape.

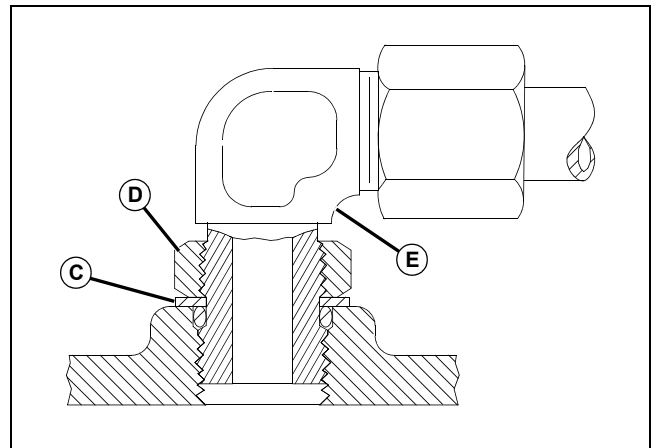

MIF

3. For angle fittings, loosen special nut (D) and push special washer (C) against threads so O-ring can be installed into the groove of fitting.
4. Turn fitting into the boss by hand until special washer or washer face (straight fitting) contacts boss face and O-ring is squeezed into its seat.
5. To position angle fittings (E), turn the fitting counter-clockwise a maximum of one turn.
6. Tighten straight fittings to torque value shown on chart. For angle fittings, tighten the special nut to value shown in the chart while holding body of fitting with a wrench.

# SPECIFICATIONS AND INFORMATION GENERAL INFORMATION

## Straight Fitting Or Special Nut Torques

| Thread Size  | Torque <sup>a</sup> |       | Number of Flats <sup>b</sup> |
|--------------|---------------------|-------|------------------------------|
|              | N•m                 | lb-ft |                              |
| 3/8-24 UNF   | 8                   | 6     | 2                            |
| 7/16-20 UNF  | 12                  | 9     | 2                            |
| 1/2-20 UNF   | 16                  | 12    | 2                            |
| 9/16-18 UNF  | 24                  | 18    | 2                            |
| 3/4-16 UNF   | 46                  | 34    | 2                            |
| 7/8-14 UNF   | 62                  | 46    | 1-1/2                        |
| 1-1/16-12 UN | 102                 | 75    | 1                            |
| 1-3/16-12 UN | 122                 | 90    | 1                            |
| 1-5/16-12 UN | 142                 | 105   | 3/4                          |
| 1-5/8-12 UN  | 190                 | 140   | 3/4                          |
| 1-7/8-12 UN  | 217                 | 160   | 1/2                          |

<sup>a</sup>Torque tolerance is ± 10 percent.

<sup>b</sup>To be used if a torque wrench cannot be used. After tightening fitting by hand, put a mark on nut or boss; then tighten special nut or straight fitting the number of flats shown.

## Metric Fastener Torque Value - Grade 7 (Special)

| Size | Steel or Gray Iron Torque | Aluminum Torque |
|------|---------------------------|-----------------|
|      | N•m (lb-ft)               | N•m (lb-ft)     |
| M6   | 11 (8)                    | 8 (6)           |
| M8   | 24 (18)                   | 19 (14)         |
| M10  | 52 (38)                   | 41 (30)         |
| M12  | 88 (65)                   | 70 (52)         |
| M14  | 138 (102)                 | 111 (82)        |
| M16  | 224 (165)                 | 179 (132)       |

## General Information

### Gasoline

#### 4 - Cycle Engines



**CAUTION: Avoid Injury!** Gasoline is **HIGHLY FLAMMABLE**, handle it with care. **DO NOT** refuel machine while: indoors, always fill gas tank outdoors; machine is near an open flame or sparks; engine is running, **STOP** engine; engine is hot, allow it to cool sufficiently first; smoking. Help prevent fires: fill gas tank to bottom of filler neck only; be sure fill cap is tight after fueling; clean up any gas spills **IMMEDIATELY**; keep machine clean and in good repair - free of excess grease, oil, debris, and faulty or damaged parts; any storage of machines with gas left in tank should be in an area that is well ventilated to prevent possible igniting of fumes by an open flame or spark, this includes any appliance with a pilot light. To prevent fire or explosion caused by **STATIC ELECTRIC DISCHARGE** during fueling: **ONLY** use a clean, approved **POLYETHYLENE PLASTIC** fuel container and funnel **WITHOUT** any metal screen or filter.

#### To avoid engine damage:

- DO NOT mix oil with gasoline;
- **ONLY** use clean, fresh unleaded gasoline with an octane rating (anti-knock index) of 87 or higher;
- fill gas tank at the end of each day's operation to help prevent condensation from forming inside a partially filled tank;
- keep up with specified service intervals.

Use of alternative oxygenated, gasohol blended, unleaded gasoline is acceptable as long as:

- the ethyl or grain alcohol blends DO NOT exceed 10% by volume or
- methyl tertiary butyl ether (MTBE) blends DO NOT exceed 15% by volume

RFG (reformulated) gasoline is acceptable for all machines designed for use of regular unleaded fuel. Older machines (that were designed for leaded fuel) may see some accelerated valve and seat wear.

# SPECIFICATIONS AND INFORMATION GENERAL INFORMATION

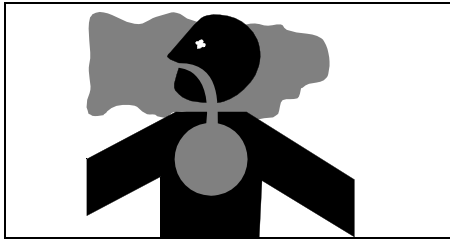

MIF

**IMPORTANT: Avoid damage! California Proposition 65 Warning: Gasoline engine exhaust from this product contains chemicals known to the State of California to cause cancer, birth defects, or other reproductive harm.**

## Gasoline Storage

**IMPORTANT: Avoid damage! Keep all dirt, scale, water or other foreign material out of gasoline.**

Keep gasoline stored in a safe, protected area. Storage of gasoline in a clean, properly marked ("UNLEADED GASOLINE") POLYETHYLENE PLASTIC container WITHOUT any metal screen or filter is recommended. DO NOT use de-icers to attempt to remove water from gasoline or depend on fuel filters to remove water from gasoline. Use a water separator installed in the storage tank outlet. BE SURE to properly discard unstable or contaminated gasoline. When storing the machine or gasoline, it is recommended that you add **John Deere Gasoline Conditioner and Stabilizer (TY15977)** or an equivalent to the gasoline. BE SURE to follow directions on container and to properly discard empty container.

## 4 - Cycle Gasoline Engine Oil

Use the appropriate oil viscosity based on the expected air temperature range during the period between recommended oil changes. Operating outside of these recommended oil air temperature ranges may cause premature engine failure.

The following John Deere oils are PREFERRED:

- **PLUS - 4® - SAE 10W-40;**
- **TORQ - GARD SUPREME® - SAE 5W-30.**

The following John Deere oils are **also recommended**, based on their specified temperature range:

- **TURF - GARD® - SAE 10W-30;**
- **PLUS - 4® - SAE 10W-30;**
- **TORQ - GARD SUPREME® - SAE 30.**

Other oils may be used if above John Deere oils are not available, provided they meet one of the following specifications:

- SAE 10W-40 - API Service Classifications SG or higher;
- SAE 5W-30 - API Service Classification SG or higher;
- SAE 10W-30 - API Service Classifications SG or higher;
- SAE 30 - API Service Classification SC or higher.

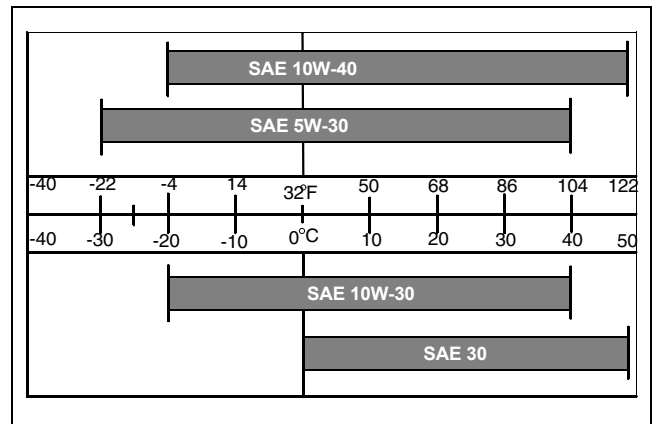

# SPECIFICATIONS AND INFORMATION GENERAL INFORMATION

## Break-In Engine Oil - 4-Cycle Gasoline

**IMPORTANT: Avoid damage! ONLY use a quality break-in oil in rebuilt or remanufactured engines for the first 5 hours (maximum) of operation. DO NOT use oils with heavier viscosity weights than SAE 5W-30 or oils meeting specifications API SG or SH, these oils will not allow rebuilt or remanufactured engines to break-in properly.**

The following John Deere oil is PREFERRED:

- **BREAK - IN ENGINE OIL.**

John Deere BREAK - IN ENGINE OIL is formulated with special additives for aluminum and cast iron type engines to allow the power cylinder components (pistons, rings, and liners as well) to “wear-in” while protecting other engine components, valve train and gears, from abnormal wear. Engine rebuild instructions should be followed closely to determine if special requirements are necessary.

John Deere BREAK - IN ENGINE OIL is also recommended for non-John Deere engines, both aluminum and cast iron types.

The following John Deere oil is **also recommended**:

- **TORQ - GARD SUPREME® - SAE 5W-30.**

If the above recommended John Deere oils are not available, use a break-in engine oil meeting the following specification during the first **5 hours (maximum)** of operation:

- SAE 5W-30 - API Service Classification SE or higher.

**IMPORTANT: Avoid damage! After the break-in period, use the John Deere oil that is recommended for this engine.**

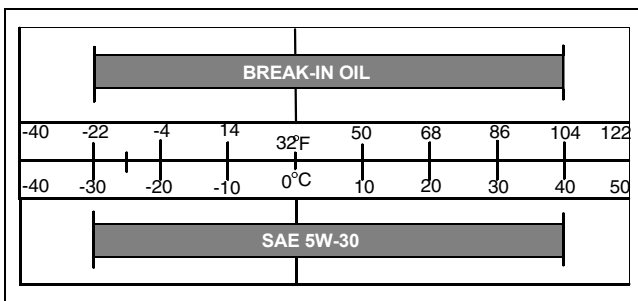

## Grease

**IMPORTANT: Avoid damage! Use recommended John Deere greases to avoid component failure and premature wear.**

The recommended John Deere greases are effective within an average air temperature range of -29 to 135 degrees C (-20 to 275 degrees F).

If operating outside that temperature range, contact your Servicing dealer for a special-use grease.

The following greases are preferred:

- John Deere Multi-Purpose HD Lithium Complex Grease
- John Deere Multi-Purpose SD Polyurea Grease

If not using any of the preferred greases, be sure to use a general all-purpose grease with an NLGI grade No.2 rating.

Wet or high speed conditions may require use of a special-use grease. Contact your Servicing dealer for information.

## Chain Lubricant

Use John Deere molybdenum disulfide (Moly) Chain & Cable Lubricant or an equivalent oil meeting John Deere specifications to lubricate drive chains. In dry dusty conditions, use of a dry lube is recommended.

## Transaxle Oil

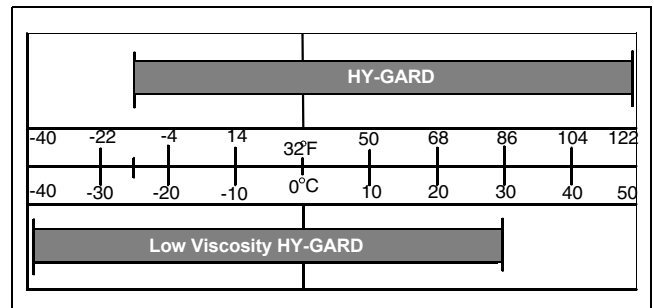

Use oil viscosity based on the expected air temperature range during the period between oil changes.

John Deere HY-GARD™ transmission and hydraulic oil is recommended for most normal operating temperatures.

**NOTE: For temperatures below -13° C (0° F) John Deere low viscosity HY-GARD™ may be used. If used at temperatures above -13° C (0° F) some brake squeal may be heard due to lower viscosity of the oil at higher temperatures.**

Other oils may be used if they meet John Deere standards JDM J20C and JDM J20D.