

JOHN DEERE
WORLDWIDE COMMERCIAL & CONSUMER
EQUIPMENT DIVISION

Walk Greens Mower
180SL, 220SL, 260SL

TM114119 DECEMBER 2010

TECHNICAL MANUAL



JOHN DEERE

North American Version
Litho In U.s.a.



DCG



TM114119

INTRODUCTION

Manual Description

This technical manual is written for an experienced technician and contains sections that are specifically for this product. It is a part of a total product support program.

The manual is organized so that all the information on a particular system is kept together. The order of grouping is as follows:

- Table of Contents
- Specifications and Information
- Identification Numbers
- Tools and Materials
- Component Location
- Schematics and Harnesses
- Theory of Operation
- Operation and Diagnostics
- Diagnostics
- Tests and Adjustments
- Repair
- Other

Note: Depending on the particular section or system being covered, not all of the above groups may be used.

The bleed tabs for the pages of each section will align with the sections listed on this page. Page numbering is consecutive from the beginning of the Safety section through the last section.

We appreciate your input on this manual. If you find any errors or want to comment on the layout of the manual please contact us.

Safety

Specifications and Information

Engine

Electrical

Power Train

Handlebar and Controls

Brakes

Cutting Unit

Miscellaneous

All information, illustrations and specifications in this manual are based on the latest information at the time of publication. The right is reserved to make changes at any time without notice.

COPYRIGHT© 2010
Deere & Co.
John Deere Worldwide Commercial and
Consumer Equipment Division
All rights reserved
Previous Editions
COPYRIGHT©

SAFETY

Safety

Recognize Safety Information



MIF

This is the safety-alert symbol. When you see this symbol on your machine or in this manual, be alert to the potential for personal injury.

Follow recommended precautions and safe servicing practices.

Understand Signal Words

A signal word - DANGER, WARNING, or CAUTION - is used with the safety-alert symbol. DANGER identifies the most serious hazards.

DANGER or WARNING safety signs are located near specific hazards. General precautions are listed on CAUTION safety signs. CAUTION also calls attention to safety messages in this manual.

Replace Safety Signs

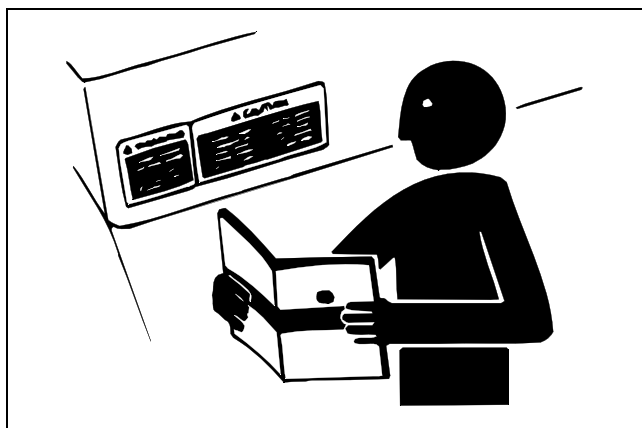

MIF

Replace missing or damaged safety signs. See the machine operator's manual for correct safety sign placement.

Be Prepared for Emergencies

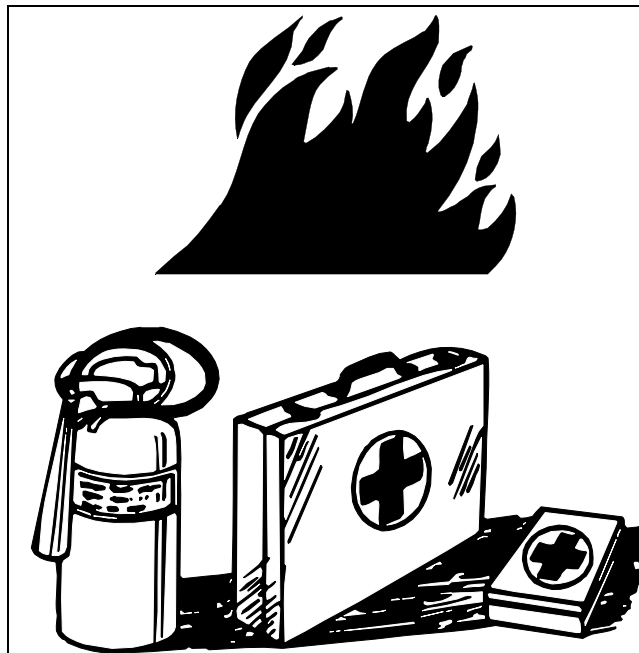

MIF

When you work around fuel, do not smoke or work near heaters or other fire hazards.

Store flammable fluids away from fire hazards. Do not incinerate or puncture pressurized containers.

Make sure machine is clean of trash, grease, and debris.

Do not store oily rags; they can ignite and burn spontaneously.

Be prepared if a fire starts.

Keep a first aid kit and fire extinguisher handy.

Keep emergency numbers for doctors, ambulance service, hospital, and fire department near your telephone.

Wear Protective Clothing

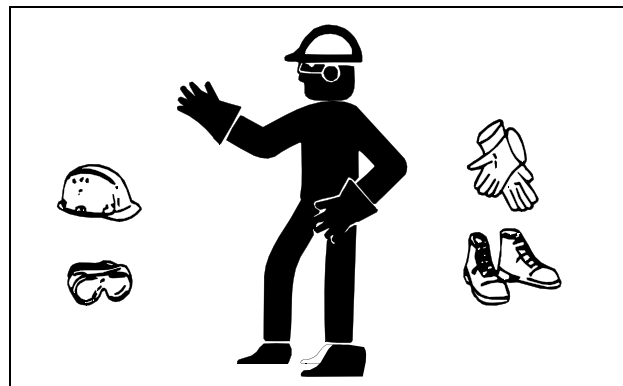

MIF

Wear close fitting clothing and safety equipment appropriate to the job.

SAFETY

Prolonged exposure to loud noise can cause impairment or loss of hearing. Wear a suitable hearing protective device such as earmuffs or earplugs to protect against objectionable or uncomfortable loud noises.

Operating equipment safely requires the full attention of the operator. Do not wear radio or music headphones while operating machine.

Service Machines Safely

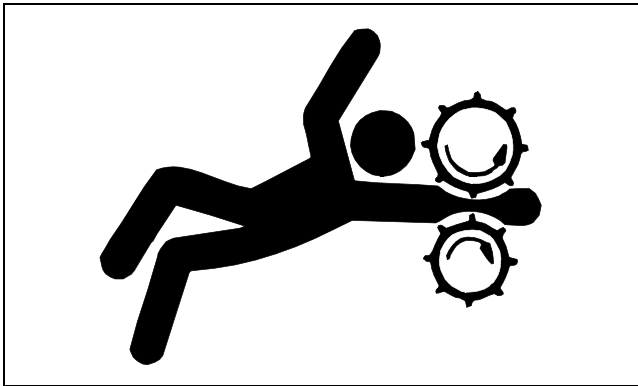

MIF

Tie long hair behind your head. Do not wear a necktie, scarf, loose clothing, or necklace when you work near machine tools or moving parts. If these items were to get caught, severe injury could result.

Remove rings and other jewelry to prevent electrical shorts and entanglement in moving parts.

Use Proper Tools

Use tools appropriate to the work. Makeshift tools and procedures can create safety hazards. Use power tools only to loosen threaded parts and fasteners. For loosening and tightening hardware, use the correct size tools. **DO NOT** use U.S. measurement tools on metric fasteners. Avoid bodily injury caused by slipping wrenches. Use only service parts meeting John Deere specifications.

Park Machine Safely

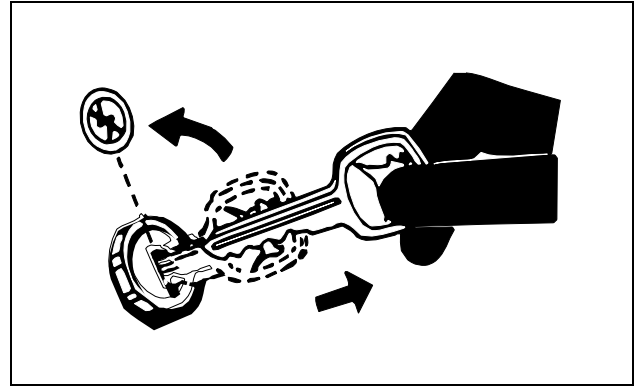

MIF

Before working on the machine:

1. Lower all equipment to the ground.
2. Stop the engine and remove the key.
3. Disconnect the battery ground strap.
4. Hang a "DO NOT OPERATE" tag in operator station.

Support Machine Properly and Use Proper Lifting Equipment

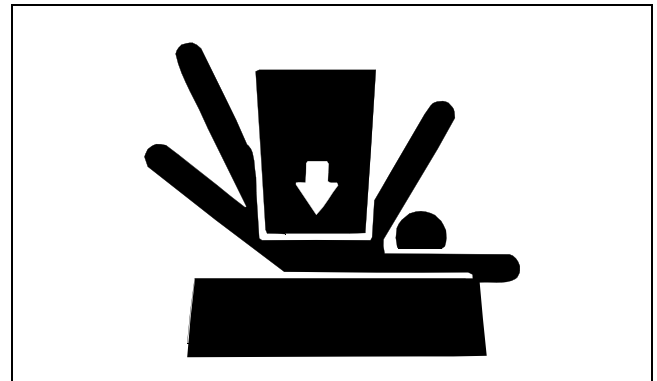

MIF

If you must work on a lifted machine or attachment, securely support the machine or attachment.

Do not support the machine on cinder blocks, hollow tiles, or props that may crumble under continuous load. Do not work under a machine that is supported solely by a jack. Follow recommended procedures in this manual.

Lifting heavy components incorrectly can cause severe injury or machine damage. Follow recommended procedure for removal and installation of components in the manual.

SAFETY

Work in Clean Area

Before starting a job:

1. Clean work area and machine.
2. Make sure you have all necessary tools to do your job.
3. Have the right parts on hand.
4. Read all instructions thoroughly; do not attempt shortcuts.

Illuminate Work Area Safely

Illuminate your work area adequately but safely. Use a portable safety light for working inside or under the machine. Make sure the bulb is enclosed by a wire cage. The hot filament of an accidentally broken bulb can ignite spilled fuel or oil.

Work in Ventilated Area

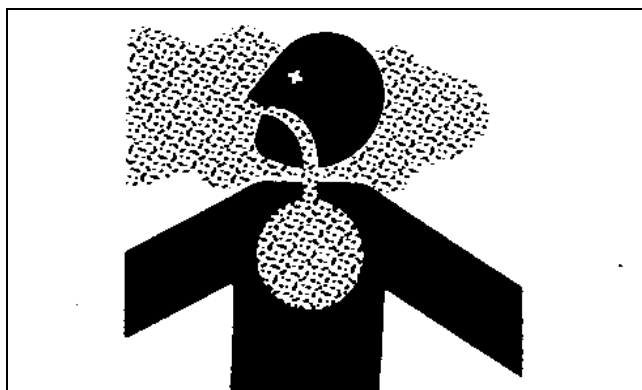

TS220

Engine exhaust fumes can cause sickness or death. If it is necessary to run an engine in an enclosed area, remove the exhaust fumes from the area with an exhaust pipe extension.

If you do not have an exhaust pipe extension, open the doors and get outside air into the area.

WARNING: California Proposition 65 Warning

Gasoline engine exhaust from this product contains chemicals known to the State of California to cause cancer, birth defects, or other reproductive harm.

Remove Paint before Welding or Heating

Avoid potentially toxic fumes and dust. Hazardous fumes can be generated when paint is heated by welding, soldering, or using a torch. Do all work outside or in a well ventilated area. Dispose of paint and solvent properly. Remove paint before welding or heating: If you sand or grind paint, avoid breathing the dust. Wear an approved

respirator. If you use solvent or paint stripper, remove stripper with soap and water before welding. Remove solvent or paint stripper containers and other flammable material from area. Allow fumes to disperse at least 15 minutes before welding or heating.

Avoid Harmful Asbestos Dust

Avoid breathing dust that may be generated when handling components containing asbestos fibers. Inhaled asbestos fibers may cause lung cancer.

Components in products that may contain asbestos fibers are brake pads, brake band and lining assemblies, clutch plates, and some gaskets. The asbestos used in these components is usually found in a resin or sealed in some way. Normal handling is not hazardous as long as airborne dust containing asbestos is not generated.

Avoid creating dust. Never use compressed air for cleaning. Avoid brushing or grinding material containing asbestos. When servicing, wear an approved respirator. A special vacuum cleaner is recommended to clean asbestos. If not available, apply a mist of oil or water on the material containing asbestos. Keep bystanders away from the area.

Service Tires Safely



MIF

Explosive separation of a tire and rim parts can cause serious injury or death.

Do not attempt to mount a tire unless you have the proper equipment and experience to perform the job. Always maintain the correct tire pressure. Do not inflate the tires above the recommended pressure. Never weld or heat a wheel and tire assembly. The heat can cause an increase in air pressure resulting in a tire explosion. Welding can structurally weaken or deform the wheel.

When inflating tires, use a clip-on chuck and extension hose long enough to allow you to stand to one side and NOT in front of or over the tire assembly. Use a safety cage if available.

Check wheels for low pressure, cuts, bubbles, damaged rims or missing lug bolts and nuts.

SAFETY

Avoid Injury from Rotating Blades, Augers, and PTO Shafts

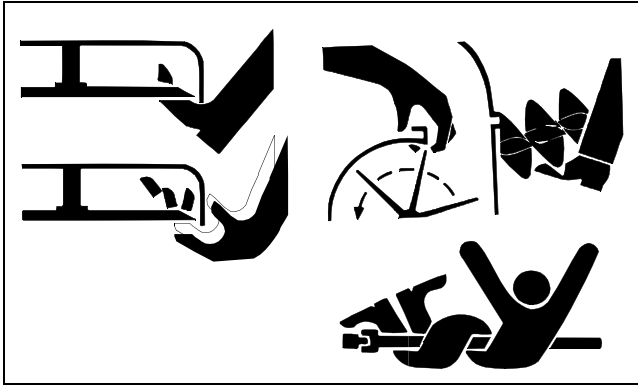

MIF

Keep hands and feet away while machine is running. Shut off power to service, lubricate or remove mower blades, augers or PTO shafts.

Handle Chemical Products Safely

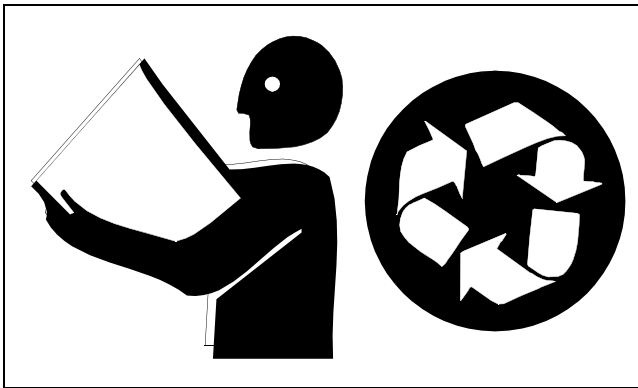

MIF

Direct exposure to hazardous chemicals can cause serious injury. Potentially hazardous chemicals used with John Deere equipment include such items as lubricants, coolants, paints, and adhesives.

A Material Safety Data Sheet (MSDS) provides specific details on chemical products: physical and health hazards, safety procedures, and emergency response techniques. Check the MSDS before you start any job using a hazardous chemical. That way you will know exactly what the risks are and how to do the job safely. Then follow procedures and recommended equipment.

Dispose of Waste Properly

Improperly disposing of waste can threaten the environment and ecology. Potentially harmful waste used with John Deere equipment includes such items as oil, fuel, coolant, brake fluid, filters, and batteries. Use leakproof containers when draining fluids. Do not use food or

beverage containers that may mislead someone into drinking from them. Do not pour waste onto the ground, down a drain, or into any water source. Inquire on the proper way to recycle or dispose of waste from your local environmental or recycling center, or from your John Deere dealer.

Live with Safety



MIF

Before returning machine to customer, make sure machine is functioning properly, especially the safety systems. Install all guards and shields.

SPECIFICATIONS AND INFORMATION TABLE OF CONTENTS

Table of Contents

Specifications	7
Machine Specifications.....	7
Repair Information.....	9
Metric Fastener Torque Values.....	9
Metric Fastener Torque Values - Grade 7....	10
Inch Fastener Torque Values.....	11
Oils and Lubricants	12
Engine Oil.....	12
Transmission and Hydraulic Oil.....	12
Biodegradable Oil.....	12
Converting From HY-GARD to BIO HY-GARD.....	13
Grease.....	13
Alternative Lubricants.....	13
Synthetic Lubricants	13
Lubricant Storage	13
Mixing of Lubricants	13
Gasoline.....	14
Using Proper Fuel	14
Serial Number Locations	14
Record Identification Numbers	14
Machine Identification Number.....	14
Engine Serial Number	14

SPECIFICATIONS AND INFORMATION TABLE OF CONTENTS



SPECIFICATIONS AND INFORMATION SPECIFICATIONS

Specifications

Machine Specifications

Note: Specifications and design subject to change without notice.

Engine

Make.....	Honda
Type.....	Gasoline, 25° inclined cylinder
Model.....	GX120
Aspiration.....	Natural
Cylinders.....	1
Displacement.....	118 cm ³ (7.2 cu in.)
Stroke/Cycle.....	4 cycle
Bore.....	60 mm (2.4 in.)
Stroke.....	42 mm (1.7 in.)
Compression Ratio.....	8.5:1
Slow Idle.....	1400 +220/-150 rpm
Fast Idle.....	2950 ± 150 rpm
Timing.....	25° BTDC
Valves.....	Overhead valves
Lubrication.....	Splash
Cooling System.....	Forced air
Air Cleaner.....	Dual-element (silent) type
Carburetor.....	Float-type
Muffler.....	In-line
Engine Oil Capacity.....	0.6 L (0.63 qt)
Type of Starter.....	Recoil
Weight.....	15.5 kg (34.2 lb)

Fuel System

Fuel Tank Location.....	On engine
Fuel Tank Capacity.....	2.5 L (0.66 gal)
Fuel (Minimum Octane).....	Unleaded gasoline, 87 octane
Fuel Delivery.....	Gravity
Carburetor.....	Float-type side draft
Fuel Filter.....	Screen

Electrical

Ignition.....	Transistorized magneto
---------------	------------------------

Drive Train/Traveling Device

Traction Roller.....	Smooth surface, dual aluminium
Forward Traveling Speed.....	9.2 km/h (5.5 mph)
Mow Traveling Speed.....	5.5 km/h (3.4 mph)
Front Roller.....	Machined steel, solid or grooved

Brakes

Park Brake.....	Band type, lever activated
-----------------	----------------------------

SPECIFICATIONS AND INFORMATION SPECIFICATIONS

Cutting Unit

180SL Cutting Width	457 mm (18 in.)
220SL Cutting Width	559 mm (22 in.)
260SL Cutting Width	660 mm (26 in.)
Cutting Height (Min, Standard 3.0 mm Bed Knife)	3.2 mm (0.126 in.)
Cutting Height (Min, Optional 2.5 mm Bed Knife)	2.8 mm (0.110 in.)
Cutting Height (Min, Optional 2.0 mm Bed Knife)	2.0 mm (0.079 in.)
Cutting Height (Max)	22.2 mm (0.874 in.)
Frequency of Clip (Standard)	4.62 mm (0.182 in.)
Frequency of Clip (Optional)	4.04 mm (0.159 in.)
Reel Diameter	127 mm (5 in.)
Reel Number of Blades (Standard)	11
Reel Number of Blades (Optional - 260SL)	7
Reel Material	Heat treated special alloy steel
Grass Catcher	Rotational molded polypropylene

Weight (Less GTC and Wheels, with Grass Catcher)

180SL	93 kg (205 lb)
220SL	100 kg (220 lb)
260SL	108 kg (238 lb)

Width

180SL	838 mm (33 in.)
220SL	940 mm (37 in.)
260SL	1041 mm (41 in.)
Length	1244 mm (49 in.)
Height	1016 mm (41 in.)







Wheels and Tires

Size	4.1/3.5-6 (2 pr) tubeless
Pressure	125-140 kPa (18-20 psi)

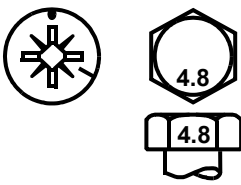
SPECIFICATIONS AND INFORMATION REPAIR INFORMATION

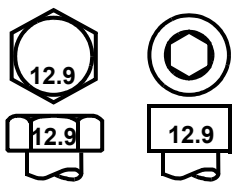
Repair Information

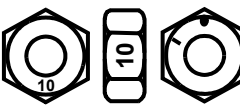
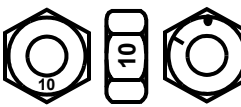
Metric Fastener Torque Values

Property Class and Head Markings	4.8 	8.8 9.8 	10.9 	12.9 
Property Class and Nut Markings	5 	10 	10 	12 

MIF (TS1163)

SIZE	Class 4.8		Class 8.8 or 9.8				Class 10.9				Class 12.9					
	Lubricated ¹		Dry ^a		Lubricated ^a		Dry ^a		Lubricated ^a		Dry ^a		Lubricated ^a		Dry ^a	
	N•m	lb-ft	N•m	lb-ft	N•m	lb-ft	N•m	lb-ft	N•m	lb-ft	N•m	lb-ft	N•m	lb-ft	N•m	lb-ft
M6	4.8	3.5	6	4.5	9	6.5	11	8.5	13	9.5	17	12	15	11.5	19	14.5
M8	12	8.5	15	11	22	16	28	20	32	24	40	30	37	28	47	35
M10	23	17	29	21	43	32	55	40	63	47	80	60	75	55	95	70
M12	40	29	50	37	75	55	95	70	110	80	140	105	130	95	165	120
M14	63	47	80	60	120	88	150	110	175	130	225	165	205	150	260	109
M16	100	73	125	92	190	140	240	175	275	200	350	225	320	240	400	300
M18	135	100	175	125	260	195	330	250	375	275	475	350	440	325	560	410
M20	190	140	240	180	375	275	475	350	530	400	675	500	625	460	800	580
M22	260	190	330	250	510	375	650	475	725	540	925	675	850	625	1075	800
M24	330	250	425	310	650	475	825	600	925	675	1150	850	1075	800	1350	1000
M27	490	360	625	450	950	700	1200	875	1350	1000	1700	1250	1600	1150	2000	1500
M30	675	490	850	625	1300	950	1650	1200	1850	1350	2300	1700	2150	1600	2700	2000
M33	900	675	1150	850	1750	1300	2200	1650	2500	1850	3150	2350	2900	2150	3700	2750
M36	1150	850	1450	1075	2250	1650	2850	2100	3200	2350	4050	3000	3750	2750	4750	3500

¹ "Lubricated" means coated with a lubricant such as engine oil, or fasteners with phosphate and oil coatings. "Dry" means plain or zinc plated (yellow dichromate - Specification JDS117) without any lubrication.

DO NOT use these hand torque values if a different torque value or tightening procedure is given for a specific application. Torque values listed are for general use only and include a ±10% variance factor. Check tightness of fasteners periodically. DO NOT use air powered wrenches.

Shear bolts are designed to fail under predetermined loads. Always replace shear bolts with identical grade.

Fasteners should be replaced with the same class. Make sure fastener threads are clean and that you properly start

thread engagement. This will prevent them from failing when tightening.

When bolt and nut combination fasteners are used, torque values should be applied to the NUT instead of the bolt head.

Tighten toothed or serrated-type lock nuts to the full torque value.

Reference: JDS-G200.









SPECIFICATIONS AND INFORMATION REPAIR INFORMATION

Metric Fastener Torque Values - Grade 7

Size	Steel or Gray Iron Torque		Aluminum Torque	
	N•m	lb-ft	N•m	lb-ft
M6	11	8	8	6
M8	24	18	19	14
M10	52	38	41	30
M12	88	65	70	52
M14	138	102	111	82
M16	224	165	179	132

SPECIFICATIONS AND INFORMATION REPAIR INFORMATION

Inch Fastener Torque Values

SAE Grade and Head Markings	1 or 2 ^a No Marks 	5 5.1 5.2 	8 8.2 
SAE Grade and Nut Markings	2 No Marks 	5  	8  

MIF (TS1162)

SIZE	Grade 1		Grade 2 ¹				Grade 5, 5.1 or 5.2				Grade 8 or 8.2					
	Lubricated ²		Dry ^b		Lubricated ^b		Dry ^b		Lubricated ^b		Dry ^b		Lubricated ^b		Dry ^b	
	N•m	lb-ft	N•m	lb-ft	N•m	lb-ft	N•m	lb-ft	N•m	lb-ft	N•m	lb-ft	N•m	lb-ft	N•m	lb-ft
1/4	3.7	2.8	4.7	3.5	6	4.5	7.5	5.5	9.5	7	12	9	13.5	10	17	12.5
5/16	7.7	5.5	10	7	12	9	15	11	20	15	25	18	28	21	35	26
3/8	14	10	17	13	22	16	27	20	35	26	44	33	50	36	63	46
7/16	22	16	28	20	35	26	44	32	55	41	70	52	80	58	100	75
1/2	33	25	42	31	53	39	67	50	85	63	110	80	120	90	150	115
9/16	48	36	60	45	75	56	95	70	125	90	155	115	175	130	225	160
5/8	67	50	85	62	105	78	135	100	170	125	215	160	215	160	300	225
3/4	120	87	150	110	190	140	240	175	300	225	375	280	425	310	550	400
7/8	190	140	240	175	190	140	240	175	490	360	625	450	700	500	875	650
1	290	210	360	270	290	210	360	270	725	540	925	675	1050	750	1300	975
1-1/8	470	300	510	375	470	300	510	375	900	675	1150	850	1450	1075	1850	1350
1-1/4	570	425	725	530	570	425	725	530	1300	950	1650	1200	2050	1500	2600	1950
1-3/8	750	550	950	700	750	550	950	700	1700	1250	2150	1550	2700	2000	3400	2550
1-1/2	1000	725	1250	925	990	725	1250	930	2250	1650	2850	2100	3600	2650	4550	3350

1. "Grade 2" applies for hex cap screws (not hex bolts) up to 152 mm (6-in.) long. "Grade 1" applies for hex cap screws over 152 mm (6-in.) long, and for all other types of bolts and screws of any length.

2. "Lubricated" means coated with a lubricant such as engine oil, or fasteners with phosphate and oil coatings. "Dry" means plain or zinc plated (yellow dichromate - Specification JDS117) without any lubrication.

DO NOT use these hand torque values if a different torque value or tightening procedure is given for a specific application. Torque values listed are for general use only and include a ±10% variance factor. Check tightness of fasteners periodically. DO NOT use air powered wrenches.

Shear bolts are designed to fail under predetermined loads. Always replace shear bolts with identical grade.

Fasteners should be replaced with the same grade. Make sure fastener threads are clean and that you properly start

thread engagement. This will prevent them from failing when tightening.

When bolt and nut combination fasteners are used, torque values should be applied to the NUT instead of the bolt head.

Tighten toothed or serrated-type lock nuts to the full torque value.

Reference: JDS-G200.

SPECIFICATIONS AND INFORMATION OILS AND LUBRICANTS

Oils and Lubricants

Engine Oil

Use oil viscosity based on the expected air temperature range during the period between oil changes.

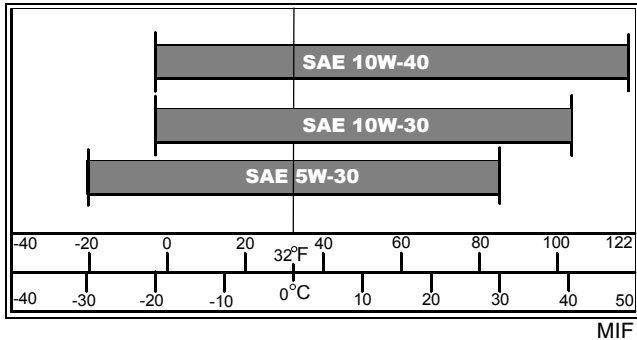

The following John Deere oils are preferred:

- TURF-GARD™
- PLUS-4™

Other oils may be used if above John Deere oils are not available, provided they meet the following specification:

- API Service Classification SG or higher

Transmission and Hydraulic Oil

Important: Avoid Damage! Machine is filled with John Deere HY-GARD™ (J20C) Transmission/Hydraulic Oil at the factory. DO NOT mix oils. DO NOT use type "F" automatic transmission fluid

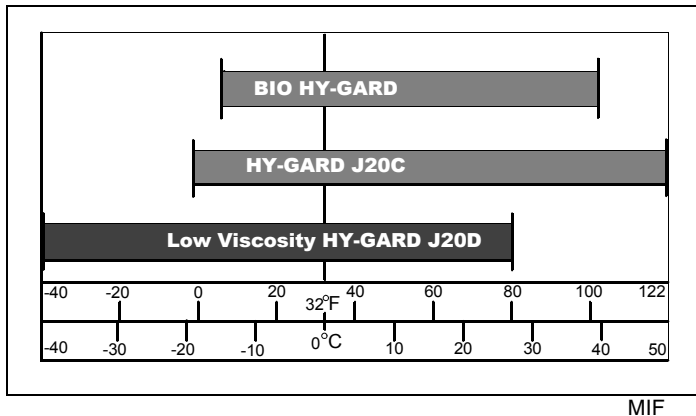

Use oil viscosity based on the expected air temperature range during the period between oil changes.

John Deere J20C HY-GARD Transmission/Hydraulic Oil is recommended. John Deere J20D Low Viscosity HY-GARD Transmission/Hydraulic Oil may also be used.

Use John Deere BIO HY-GARD™ oil when a biodegradable fluid is required.

Other oils may be used if they meet John Deere standard JDM J20C or J20D.

Biodegradable Oil

Application

Important: Avoid Damage! Biodegradable oils, other than BIO HY-GARD™, are not recommended.

When use of a biodegradable lubricant is desired or required, BIO HY-GARD is recommended. BIO HY-GARD may be used under normal mowing conditions.

DO NOT USE biodegradable lubricants in machines for the following operations:

- Any machine used for scalping procedure.
- Any verticut operation in temperatures exceeding 32°C (90°F).
- If the natural color of the fluid has become black, it is possible an overheating problem exists. Change the fluid.
- If the fluid becomes milky, water contamination may be a problem. Investigate the source of the contamination.
- Take fluid level reading when system is cold.
- Mixing of biodegradable oil and mineral oil will reduce the biodegradability of the lubricant in the machine. Mixing of HY-GARD and BIO HY-GARD will not result in performance deterioration.

Cold Weather Operation

Precautions should be taken if BIO HY-GARD containers or equipment are stored for long periods of time in extremely cold temperatures. Freezing should be expected if BIO HY-GARD is subjected to the following temperatures:

- Stored for six months at -18° to -23°C (-1° to -10°F)
- Stored for seven days at -23° to -26°C (-10° to -15°F)
- Stored for three days at -26° to -29°C (-15° to -20°F)
- Stored for two days at -29° to -34°C (-20° to -30°F)
- Stored for one day at -34°C (-30°F) and below.

Important: Avoid Damage! Equipment should not be started or any operation attempted until BIO HY-GARD has reached a safe operating viscosity.

If freezing of BIO HY-GARD is suspected, the container or equipment **MUST** be warmed to at least 0°C (32°F) and maintained for 24-48 hours to ensure the fluid has reached a safe operating viscosity.

Converting From HY-GARD to BIO HY-GARD

Systems being converted from HY-GARD to BIO HY-GARD should follow the procedure listed below to obtain maximum lubricant biodegradability.

1. Park machine on a level surface.
2. Stop engine and lock park brake.
3. Drain gearcase.
4. Fill gearcase with BIO HY-GARD to appropriate level.
5. Start engine and bring to medium idle.
6. Cycle cutting reel several times.
7. Stop engine and check hydraulic oil level. Add BIO HY-GARD to appropriate level.
8. Operate machine under normal operating conditions for a minimum of two hours.
9. Repeat steps 1-7.
10. Follow recommended maintenance schedules.

Grease

Important: Avoid Damage! Use recommended John Deere greases to avoid component failure and premature wear.

The recommended John Deere greases are effective within an average air temperature range of -29 to 135 degrees C (-20 to 275 degrees F).

If operating outside that temperature range, contact your Servicing dealer for a special-use grease.

The following greases are preferred (this may change for high speed applications such as cutting units):

- John Deere Multi-Purpose SD Polyurea Grease

If not using any of the preferred greases, be sure to use a general all-purpose grease with an NLGI grade No. 2 rating.

Wet or high speed conditions may require use of a special-use grease. Contact your Servicing dealer for information.

Alternative Lubricants

Conditions in certain geographical areas outside the United States and Canada may require different lubricant recommendations than the ones printed in this technical manual or the operator's manual. Consult with your John Deere Dealer, or Sales Branch, to obtain the alternative lubricant recommendations.

Important: Avoid Damage! Use of alternative lubricants could cause reduced life of the component.

If alternative lubricants are to be used, it is recommended that the factory fill be thoroughly removed before switching to any alternative lubricant.

Synthetic Lubricants

Synthetic lubricants may be used in John Deere equipment if they meet the applicable performance requirements (industry classification and/or military specification) as shown in this manual.

The recommended air temperature limits and service or lubricant change intervals should be maintained as shown in the operator's manual.

Avoid mixing different brands, grades, or types of oil. Oil manufacturers blend additives in their oils to meet certain specifications and performance requirements. Mixing different oils can interfere with the proper functioning of these additives and degrade lubricant performance.

Lubricant Storage

All machines operate at top efficiency only when clean lubricants are used. Use clean storage containers to handle all lubricants. Store them in an area protected from dust, moisture, and other contamination. Store drums on their sides. Make sure all containers are properly marked as to their contents. Dispose of all old, used containers and their contents properly.

Mixing of Lubricants

In general, avoid mixing different brands or types of lubricants. Manufacturers blend additives in their lubricants to meet certain specifications and performance requirements. Mixing different lubricants can interfere with the proper functioning of these additives and lubricant properties which will downgrade their intended specified performance.

SPECIFICATIONS AND INFORMATION GASOLINE

Gasoline

Using Proper Fuel

Use regular grade unleaded fuel with an octane rating of 87 octane or higher. Fuel blends containing up to 10% ethanol or up to 15% MTBE reformulated fuel are acceptable. Do not use fuel or additives containing methanol as engine damage can occur.

Always use fresh, clean fuel that is purchased in a quantity that can be used within approximately 30 days, or add fuel stabilizer.

Fuel is blended to give best seasonal performance. To avoid engine performance problems such as hard starting or vapor lock, use in-season fuel. Use fuel during warm weather that was purchased during that season, and use fuel during cold weather that was purchased during that season.

Fuel can become stale in machines with engines that are used seasonally or infrequently during a season. Stale fuel can produce varnish and plug carburetor or injector components which can affect engine performance.

Keep fuel storage container tightly covered and in a cool area out of direct sunlight. Fuel can break down and degrade if not sealed properly or exposed to sun and heat.

Condensation may collect in the fuel tank because of a variety of operating or environmental conditions and, over time, may affect your machine's operation. Fill fuel tank at the end of daily use and store fuel in plastic containers to reduce condensation.

For best year-round performance and fuel-handling, add stabilizer to fuel immediately after fuel purchase. Such practice helps prevent engine performance problems and allows fuel storage in the machine all year without draining.

Serial Number Locations

Record Identification Numbers

When ordering parts or submitting a warranty claim, it is **IMPORTANT** that the machine product identification and component serial numbers are included.

The location of the machine identification number and component serial numbers are shown.

Machine Identification Number

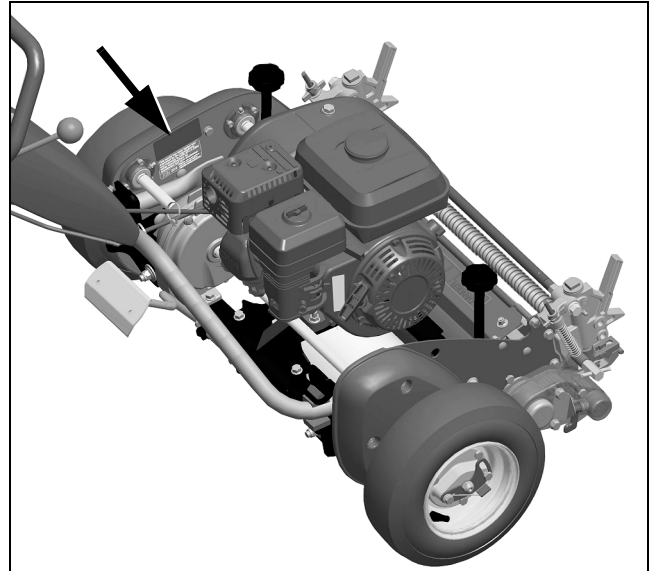

MX46471

Engine Serial Number

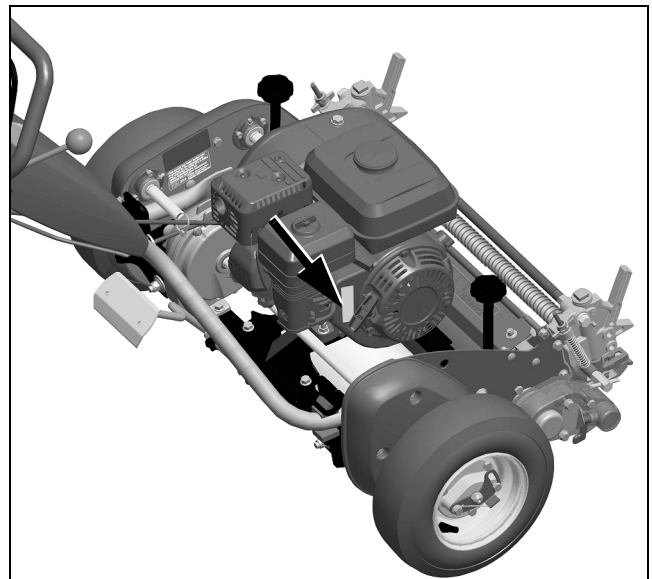

MX46471

ENGINE TABLE OF CONTENTS

Table of Contents

Specifications	17
General Specifications	17
Test and Adjustment Specifications	17
Repair Specifications.....	17
Tools and Materials	21
Special or Essential Tools	21
Other Materials.....	21
Component Location and Operation	22
External Engine Components.....	22
Internal Engine Components.....	24
Lubrication System Operation	25
Cooling System Operation	27
Diagnostics	28
Engine Cranks but Will Not Start.....	28
Engine Malfunctions at Low RPM	28
Engine Malfunctions at High RPM.....	29
Excessive Oil Consumption.....	30
Engine Overheats.....	30
Excessive Fuel Consumption	30
Tests and Adjustments	32
Check and Adjust Throttle Cable.....	32
Adjust Slow Idle Speed	32
Adjust Governor and Fast Idle Speed	33
Test Cylinder Compression Pressure	33
Check and Adjust Valve Clearance.....	34
Test Spark	35
Adjust Spark Plug Gap	36
Repair	37
Remove and Install Fuel Tank	37
Remove and Install Fuel Filter	38
Remove and Install Throttle Cable	38
Remove and Install Muffler	38
Remove and Install Engine	39
Remove and Install Air Cleaner Assembly ..	40
Service of Air Cleaner	41
Remove and Install Throttle Plate Assembly	42
Remove and Install Carburetor	42
Disassemble and Assemble Carburetor	44
Clean and Inspect Carburetor	45
Replace Pilot Screw and Limiter Cap	45
Adjust Float Level	46
Remove and Install Blower Housing Assembly	46

Remove and Install Recoil Starter	47
Disassemble and Inspect Recoil Starter	47
Assemble Recoil Starter	48
Remove and Install Ignition Coil	49
Adjust Air Gap	50
Test Ignition Coil	50
Remove and Install Flywheel	51
Remove and Install Rocker Arm Cover	51
Remove and Install Cylinder Head and Valves	52
Disassemble and Assemble Cylinder Head and Valves	53
Inspect Cylinder Head and Valves	53
Replace Valve Guide	55
Analyze Valves	56
Recondition Valve Seats.....	57
Lap Valves.....	58
Remove and Install Crankcase Cover	58
Replace Bearing and Oil Seal	59
Remove and Install Camshaft and Tappets ..	59
Inspect Camshaft and Tappets	60
Remove Piston and Connecting Rod	61
Inspect Piston and Connecting Rod	61
Disassemble Piston and Connecting Rod ..	62
Assemble Piston and Connecting Rod	62
Inspect Piston and Connecting Rod	63
Check Connecting Rod Side Play.....	65
Check Connecting Rod-to-Crankshaft Clearance	66
Check Piston Ring End Gap.....	66
Analyze Piston Ring Wear	67
Analyze Piston Wear	68
Remove and Install Crankshaft	69
Inspect Crankshaft	69
Replace Timing-Governor Gear	70
Analyze Crankshaft and Connecting Rod Wear	70
Inspect Cylinder Block	71
Inspect and Replace Bearing	71
Replace Oil Seal	72
Deglaze Cylinder Bore.....	72
Rebore Cylinder Block.....	72
Remove and Install Governor	73

ENGINE TABLE OF CONTENTS

